

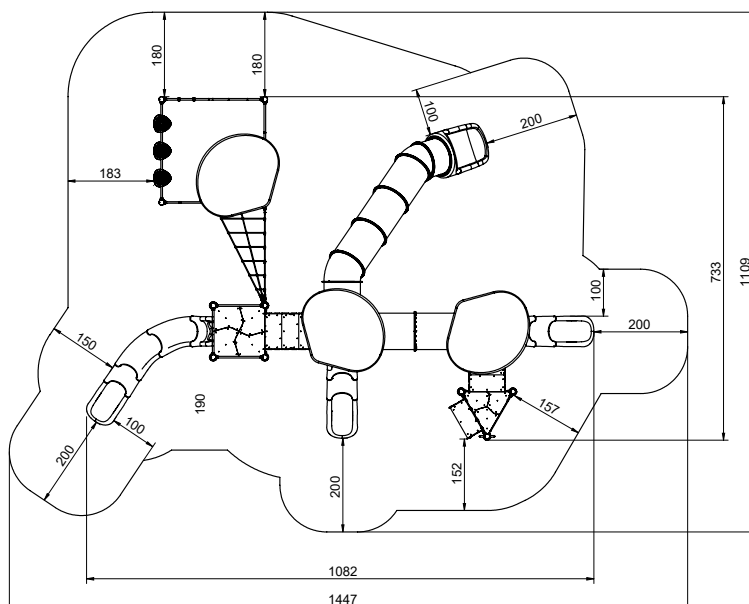

Afmetingen	1082 x 733 x 599 cm
Vrije ruimte	1447 x 1109 cm
Valhoogte	270 cm
Voldoet aan NEN EN 1176 – 1 : 2017	Ja
Leeftijdscategorie	3 - 12

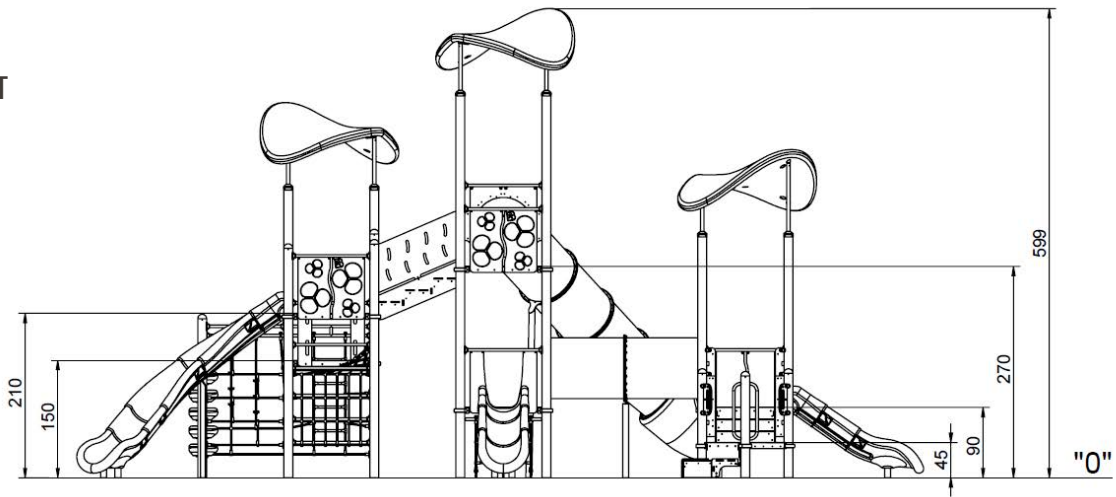

OVERZICHT



MATERIAALSPECIFICATIES



Stevige constructie gemaakt van metaal, gereinigd tijdens het zandstraalproces. De staanders worden beschermd tegen corrosie door de QUALICOAT polyester verf.



Systeem van verbindingstukken en klemmen gemaakt van aluminium.



Panelen gemaakt van kleurrijk 15 mm HDPE, volledig vocht- en UV bestendig.



Panelen en platformen gemaakt van kleurrijk 13 mm HPL, volledig vocht- en UV bestendig.



Klimgrepen van kleurrijk polyester.



Anti-slip platformen van 10 mm HPL met een zeer hoge weerstand tegen weersinvloeden en slijtage.



Modules vervaardigd uit rotatiegegoten polyethyleen.



Ergonomisch gevormde polyethyleen ringen voor het verbeteren van de motorische coördinatie.



Kunststof afdekdoppen.



Platformen gemaakt van gegalvaniseerde platen bedekt met de hoogste kwaliteit 6 mm anti-slip HPL platen.



Touw uiteinden geperst in een huls van aluminium.



Stevige touwverbinders van polyamide.



Traptreden touwladder en touwknopen van kunststof.



Polypropyleen touwen met stalen kern

15 Ellipsvormige daken gemaakt van LDPE.

16 Modulaire glijbanen gemaakt van polyethyleen.

